

SUSTAINABLE ELECTRICITY SUPPLIES FOR THE ISLE OF EIGG

A report by Hugh Piggott, Scoraig Wind Electric
For the Isle of Eigg Heritage Trust
January 2003

DRAFT FOR COMMENTS

TABLE OF CONTENTS.....	1
Overview	2
Section 1. Pros and cons of renewable energy.....	2
Section 2 : Questionnaire.....	2
Section 3: . Electricity supply requirements	2
Section 4: The renewable energy resources of the island	2
Section 5: The suggested model for electricity supply	2
1. Pros and cons of renewable energy.....	3
Why we need renewable energy.....	3
Problems with renewable energy.....	3
Household Scale, Area Grid or National Grid systems?	3
2. Questionnaire.....	5
Introduction.....	5
1. About yourselves	6
2. Your existing Power Supply	6
3. Your appliances.....	8
4. Your future power supply	9
5. Your priorities.....	10
6. Your suggestions.....	11
3. Electricity supply requirements	14
4. The renewable energy resources of the island.....	16
1. Wind Energy.....	16
2. Solar (Photovoltaic) Energy.....	18
3. Hydro Energy.....	20
4. Wave and Tidal Energy.....	24
5. The suggested model for electricity supply	24
1. The options for electricity supply are as follows:	24
2. The way forward	25
3. Stand alone system costs	26
4. Island wide system outline with costs.....	27
Conclusion	29

Overview

This report for the Isle of Eigg Heritage Trust seeks to identify the best strategy for meeting the electrical needs of the island in a sustainable way. Additional resources, links and software can be found at the web address printed in the footer of each page.

Section 1. Pros and cons of renewable energy

Renewable energy sources (energy from wind, water and sunshine) are the only energy sources that can ultimately provide electricity in a sustainable way. We consider the practical implications of maximising renewable energy use on the small scale.

Section 2 : Questionnaire

Popular support and community involvement are key issues for successful development of renewable resources in the UK. A questionnaire was used to gather information on present electricity usage, and future preferences among Eigg residents. Several options emerged, including diesel generator power, small hydro turbines, wind and solar power.

Opinion on the island favoured the continued use of diesel power as a backup source, while exploiting the abundant renewable resources of the island for the bulk of the energy required. Reliability is also an important consideration, and most islanders would like to have uninterrupted power delivered to them. Some islanders desire a connection to the mains electricity grid, because of its reliability.

Section 3: . Electricity supply requirements

The first step in designing any electricity supply is to estimate the demand. Demand is described in two ways: the peak (instant) power demand and the total demand for energy over a given period. Power (kW) is the rate of consumption of energy at one instant, whereas energy (kWh) is the accumulation of electricity consumed over a period.

It is usually safe to assume that demand will increase over time until all of the affordable energy is used. This process is typical of our consumer society, which is intrinsically unsustainable. A sustainable strategy will instead use energy conservation measures, to improve our enjoyment of the benefits of electricity while reducing our actual demand for energy.

Section 4: The renewable energy resources of the island

Hydro and wind turbines are already in use on the island, as are solar 'PV' panels. In section 2 we look at the scale of the available resources, and the best sites where their use can be expanded.

There is very little hard data for water run-off, windspeed or insolation on the island. Instead this report relies on computer software packages to predict the energy capture of different types of renewable energy equipment.

Experience has shown that reality is different from software predictions in most cases, but the software gives us a starting point for planning an overall strategy. It would be prudent to monitor the renewable resources (windspeeds, water flows, etc) at several sites and to datalog the daily production of pilot installations so as to verify the conclusions of the computer models.

Section 5: The suggested model for electricity supply

In view of the high cost of grid connection, this report favours independent power supplies based on a variety of renewable sources, some of which will be communally operated. Stand-alone electricity systems consist of more than just turbines and solar panels. Energy has to be gathered, stored and converted for use as required. We propose that each house should have its own core system, based on a battery and a back up generator.

A network of wind and hydro turbines can be used to provide the bulk of the energy required, supplemented by solar 'PV' arrays at each building. A pilot project using a centralised hydro to feed several battery systems is under construction at Kildonnan on the island. Similar schemes could be developed to form a network of independent cells which cover the whole island.

1. Pros and cons of renewable energy

Why we need renewable energy

Renewable energy is plentifully available all around us every day, and there are no particular technical obstacles to harnessing it. Wind and water power have been in use long before the invention of combustion engines, and it seems likely that they will be the chosen technology in the future, when we shall have to reduce our unsustainable reliance on fossil fuels. Renewable energy production causes no CO₂ emissions nor does it consume fuel resources, after the initial manufacture and installation of the turbines, solar panels and infrastructure required. Using renewable energy frees us from dependence on imported fuels, and sets an example for developing countries. Most of the world's population could not possibly use fuels resources on the scale they are used in the west. If the entire world tried to live the lives we live now in the UK, then the planet would immediately choke to death.

Problems with renewable energy

The biggest problem with renewable energy is the high capital cost.

The energy is diffuse and demands large structures to collect and convert it. The equipment is expensive and comes with a large amount of infrastructure. There is an 'energy cost' associated with manufacturing renewable energy equipment. This investment has to be redeemed before it can be said to produce a net energy output. The time required to pay back the energy cost of manufacture is generally quite small in terms of the life expectancy of the system (often less than one year) but it can be longer in the case of small systems.

Environmental impact is the next big problem.

Wind turbines for example are visually prominent by nature, and will change the character of the landscape to an extent. Some people like to see them, and others do not. Hydro systems divert water from its natural course into pipes and through turbines. This will have some impact on the ecology and amenity of the watercourse. These impacts must be weighed up against the impacts of alternative 'conventional' energy sources, if a rational decision is to be made. We need energy to fulfill our aspirations for lifestyle and survival, so environmental impact of some sort is inevitable.

A third problem with renewable energy is its intermittency.

Unlike fossil fuel, the source cannot be controlled to match demand. The energy is not available all the time, and may not even be easy to predict. To match supply to demand, it may be necessary to store energy, or to reschedule our use of energy, or to use a mixture of different energy sources. This consideration in itself increases the cost and environmental impacts of the energy we ultimately use at our convenience. ON the small scale, we use batteries to store the energy for later use. A device called an 'inverter' delivers mains voltage power from the batteries on demand.

Household Scale, Area Grid or National Grid systems?

It has been pointed out that small renewable energy equipment is inefficient compared with 'utility scale' windfarms, or even the intermediate scale turbines which supply the neighbouring island of Muck. There are several arguments for using small-scale renewables on this island:

Larger scale systems require very expensive distribution networks

The cost of a grid connection cable to Eigg has been estimated at £2 million. While this is less than the cost of the unpopular pier development, it is not clear that anyone will pay for it. In any case it is arguable that the money could be better spent on appropriately sized renewable energy equipment. This year, the UK government is launching grants to support the development of small renewables. It will be more cost-effective to site these renewable sources at the point of use than to install an undersea cable. And small renewables can deliver the required energy at lower capital cost than the cost of the transmission cable alone.

An electricity network could be attractive, especially for those who would like to obtain a 'turnkey' connection, but again the cost is a consideration. The cost of an island-wide distribution network has been estimated at over £300,000 (Scottish Power, April 2000). Many islanders have expressed a willingness to undertake maintenance and repair of community based energy systems (see part 2, question 4g). It should not be necessary for any unwilling individual to get his/her hands dirty.

The self-reliant lifestyle of the island is part of its appeal

Visitors are a substantial part of the island's economy. They come for many reasons, including the wild life, scenery, fresh air and cultural events. Part of the attraction is the island lifestyle, including the difficult access and the unconventional electricity supplies. Small renewable energy systems are something to be proud of and an added bonus for visitors.



Human-scale community-based renewable energy systems literally place the power in the hands of the local people. Or at least that is how it can be perceived.

2. Questionnaire

The questionnaire was distributed during the winter 2001-2. 30 forms were returned, and most were fully completed. This section includes the original questions, and some analysis of the results.

Replies represented approximately 40 islanders, but the opinions expressed may have been those of the person who filled in the form rather than the household. In one case two forms were returned with very different opinions from the same house.

While imperfect, the results must nevertheless help to reflect the views of those decision-makers who would wish to see improved electricity supply options on the island.

The questionnaire began with the following introductory passage.

INTRODUCTION (by Hugh Piggott for Eigg Trust)

I am very pleased to have been asked to prepare a report on the options for sustainable electricity supplies on the Island. The best first step is to gather wisdom from you, the residents, so that I can put forward proposals based on common sense and local knowledge. For my own part I can add some technical analysis, and projected costs.

My own preference is for small-scale, renewable energy systems using wind and hydro (free, clean energy) on a domestic scale. There are other ways to provide electricity to the island. Some options are more sustainable than others are. They range from individual diesel generator sets (as in the past) through to a connection with the national grid.

For example, Scottish Power has already proposed a scheme to power the island, from mainly renewable sources. Their scheme uses an island-wide network and would cost £900,000. In contrast, residents are about to build a smaller water powered project at Kildonnán. It is an example of a 'community' scheme, which is therefore able to attract substantial grants toward the £40,000 cost.

CONFIDENTIALITY

If you have any doubts about this questionnaire, please talk to from the Eigg Trust and he/she will explain what it is about. You are (obviously) free to refuse to answer these questions. That would be a pity because your views might not be understood. Much work can be avoided if we can learn what you want now, and not have to deal with unforeseen objections later.

We hope that you will answer as many questions as you comfortably can. Please feel free to add extra comments as well. If you would like your answers to remain confidential, then we shall not reveal your name. If you are happy to make your views public, that is better still. If members of your household have various differing views, you can try to include them all here, or ask for separate forms.

Thanks for your feedback.

QUESTIONS

1. About yourselves

Would you like all of your replies to these questions to be treated as confidential information (yes/no)?

Only two respondents asked for confidentiality. Two other respondents did not give their names.

If you wish, you can tell me some details of people who live with you - their names, their ages, and how many months of each year do they spend here?

<i>Name</i>					
<i>Age</i>					
<i>Months per year spent on Eigg</i>					

<i>Name</i>					
<i>Age</i>					
<i>Months per year spent on Eigg</i>					

Roughly how many of the above will still be resident in ten years time (if you care to guess)?

This information was useful for determining the location and needs of the respondents. None had plans to leave the island.

2. Your existing Power Supply

<i>a) What is your main source of electric power at present?</i>	
<i>b) Do you use any other sources of electricity?</i>	
<i>c) For about how many hours each day do you have power available?</i>	
<i>d) How much does it cost (roughly) each year to run this system?</i>	
<i>e) How reliable is your electricity supply?</i>	
<i>f) How happy are you with this arrangement?</i>	

Question 2 yielded interesting statistics

Most of the respondents used diesel generation for all of their power. About half of these used batteries/inverters to maintain a 24-hour power supply. Reported costs for running diesel generators varied from £150 to £7,000 per annum.

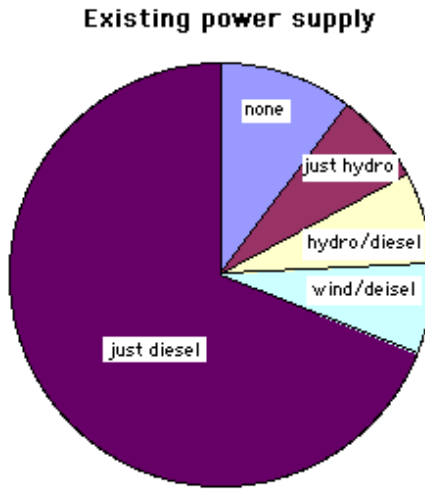

£500 would be a typical figure for diesel running costs. Most reported fairly reliable operation.

Running costs per annum

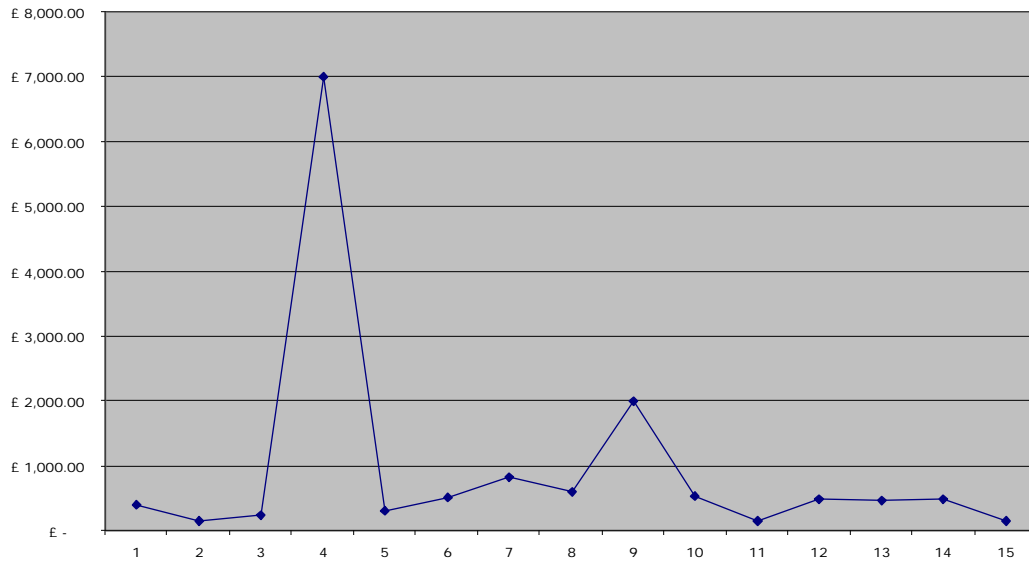

Hydro turbine users experience a higher degree of satisfaction in most cases.

3. Your appliances

Which of the following electrical appliances do you use at present, and which others would you use in future?

	<i>At present</i>	<i>In future</i>
<i>Lights</i>		
<i>Radio/stereo</i>		
<i>TV / VCR</i>		
<i>Satellite dish system</i>		
<i>Computer</i>		
<i>Fridge</i>		
<i>Freezer</i>		
<i>Dishwasher</i>		
<i>Water heater</i>		
<i>Power tools</i>		
<i>Vacuum cleaner</i>		
<i>Telephone answering machine/fax</i>		
Other...		

Use of appliances

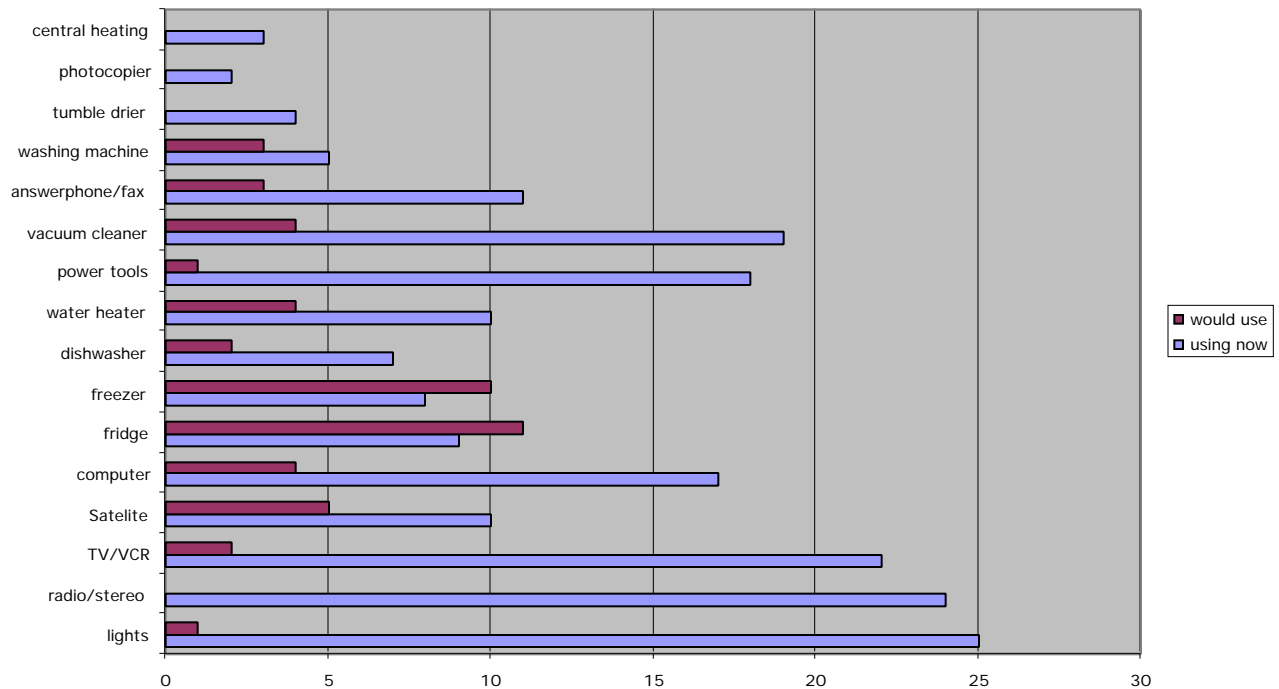

Results were as above. The 'would use' figures are for items mentioned which were not already in use. Extra items added by respondents include washing machine and central heating pump. Some users may have forgotten to add these to the list.

The residents do have aspirations to use more electrical appliances than they have at present, especially fridges and freezers where 24-hour power is required.

4. Your future power supply

a) Listed below are some alternative power supply options. Please rank them in order of preference: 1,2,3 etc.

	Order of preference
A purely private supply,	
A private supply supplemented by a community scheme,	
A community based supply,	
A 'mains grid' type of supply,	
other	
(Please describe)?	

Mains electricity was a popular option, but was also many people's last choice. A private supply

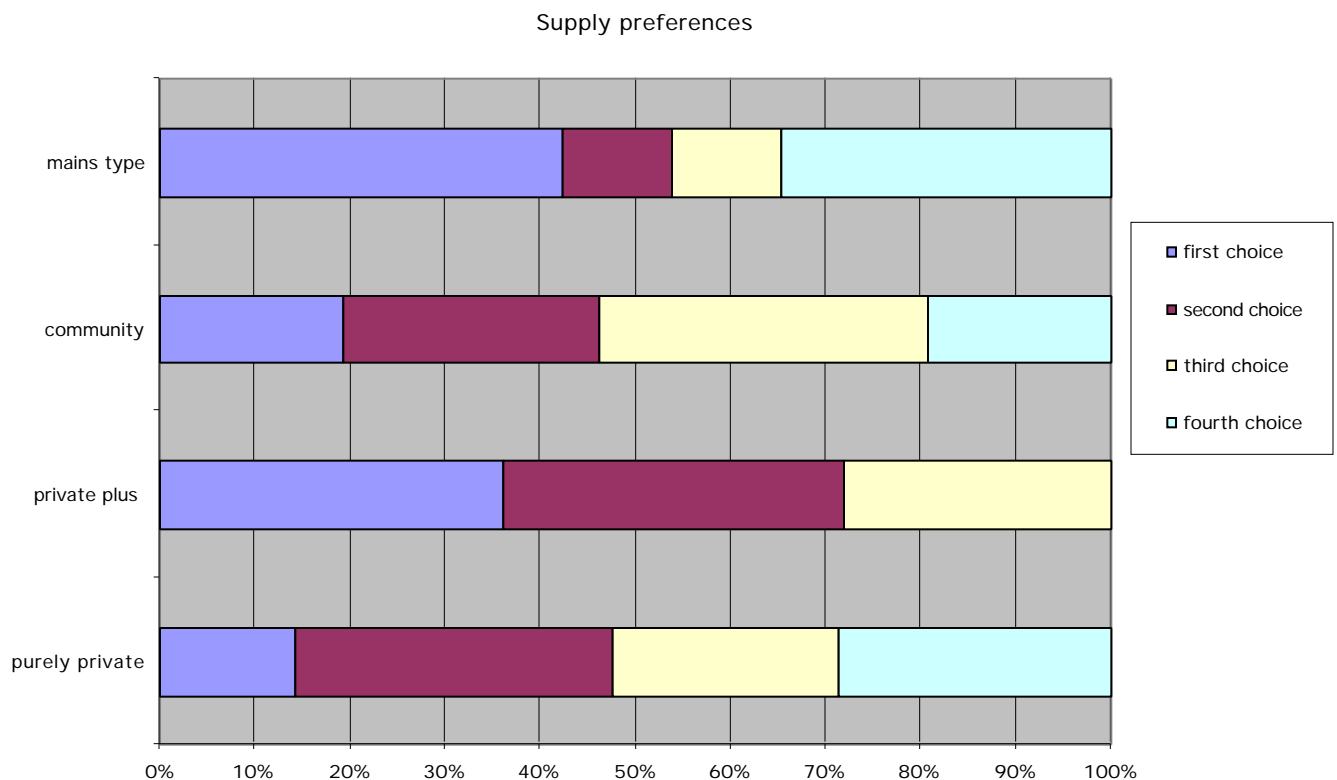

supplemented by a community supply was the most widely popular. The least popular option was the purely private supply. Individual power supplies are burdensome to maintain. Many would prefer to have power supplied to them.

b) Would you want to have more power available, and if so how much more?

c) Would you be willing to pay for a more expensive electricity supply?

d) Would you be willing to contribute (in cash or labour) toward the creation of a community scheme?

Most respondents felt that they could use more power, and would like 24-hour power. They would pay or contribute if they felt it was to their advantage. Many of the islanders have very limited financial resources.

e) Would you be willing to offer practical help with the ongoing maintenance of any electricity system?

f) Would you be interested in learning how to repair the system?

g) Would you be interested in becoming a paid caretaker on a communal system?

There was a good response to these questions. Approximately half of the respondents would consider becoming caretakers for a communal system.

5. Your priorities

Please say how important each of the following considerations are to you?

PLEASE TICK ONE BOX ON EACH LINE	Critically important	Very important	Important	Marginal	Doesn't matter
	<i>Cost of the electricity</i>				
	<i>Reliability of the supply</i>				
	<i>A 24 hour, un-interrupted supply</i>				
	<i>Independence from fuel deliveries</i>				
<i>Quiet operation</i>					
<i>Inconspicuous generating equipment (sheds, pipes, masts, etc)</i>					
<i>Environmentally friendly, non-polluting, with no CO2 emissions</i>					

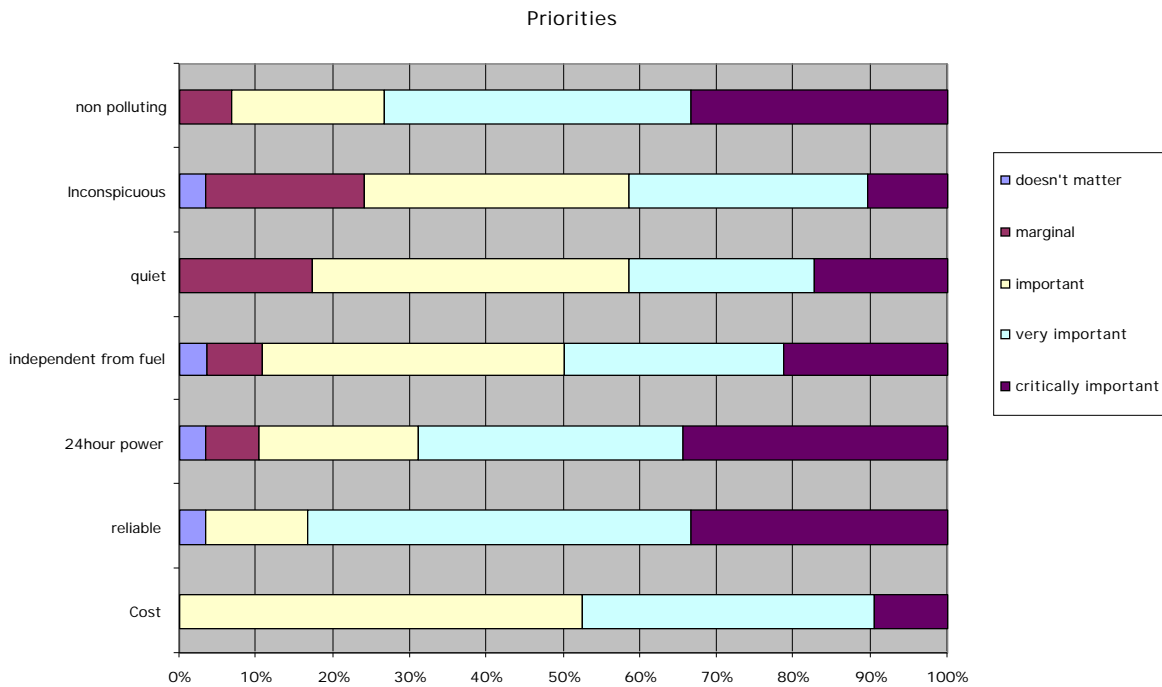

Reliable, non-polluting, 24-hour power supplies came out most popular in these replies. These factors ranked well ahead of noise and visual impact for most respondents.

6. Your suggestions

a) Do you know of any existing opportunities for making electricity near to your home or elsewhere which you would like to see harnessed? These could be sites for water turbines, wind turbines or any other type of electricity generating equipment.

Several respondents suggested suitable sites for small hydro development (Sandavore burn and smaller sites close to houses). There was no mention of Laig. Windpower sites were identified at Galmisdale and Kildonnan, but with reservations about the visual impact of the latter. There was also some enthusiasm for wood-chip combustion, wave and tidal power and for solar panels.

b) Do you know of any records, which have been kept of rainfall, wind or other relevant data, which could help us to assess what can be done on the island?

Donald MacLean has paper records of rainfall between 1927 and 1991 in his possession. They are in the form of monthly totals and number of dry days.

In view of the uncertainties surrounding the flow duration curves for island sites, it would be more useful to collect flow information at various sites than to analyse the rainfall patterns on the island.

c) How do you feel about the appearance of electricity generating equipment on the island?

PLEASE TICK ONE BOX ON EACH LINE OR WRITE YOUR OWN COMMENTS	<input type="checkbox"/>	<input type="checkbox"/>	<input type="checkbox"/>	<input type="checkbox"/>	<input type="checkbox"/>	<input type="checkbox"/>	<input type="checkbox"/>	<input type="checkbox"/>	<input type="checkbox"/>
	<input type="checkbox"/>	<input type="checkbox"/>	<input type="checkbox"/>	<input type="checkbox"/>	<input type="checkbox"/>	<input type="checkbox"/>	<input type="checkbox"/>	<input type="checkbox"/>	<input type="checkbox"/>
	<input type="checkbox"/>	<input type="checkbox"/>	<input type="checkbox"/>	<input type="checkbox"/>	<input type="checkbox"/>	<input type="checkbox"/>	<input type="checkbox"/>	<input type="checkbox"/>	<input type="checkbox"/>
	<input type="checkbox"/>	<input type="checkbox"/>	<input type="checkbox"/>	<input type="checkbox"/>	<input type="checkbox"/>	<input type="checkbox"/>	<input type="checkbox"/>	<input type="checkbox"/>	<input type="checkbox"/>
	<input type="checkbox"/>	<input type="checkbox"/>	<input type="checkbox"/>	<input type="checkbox"/>	<input type="checkbox"/>	<input type="checkbox"/>	<input type="checkbox"/>	<input type="checkbox"/>	<input type="checkbox"/>
Diesel generators in sheds	<input type="checkbox"/>	<input type="checkbox"/>	<input type="checkbox"/>	<input type="checkbox"/>	<input type="checkbox"/>	<input type="checkbox"/>	<input type="checkbox"/>	<input type="checkbox"/>	<input type="checkbox"/>
Water turbine equipment and pipelines	<input type="checkbox"/>	<input type="checkbox"/>	<input type="checkbox"/>	<input type="checkbox"/>	<input type="checkbox"/>	<input type="checkbox"/>	<input type="checkbox"/>	<input type="checkbox"/>	<input type="checkbox"/>
Wind turbines on masts	<input type="checkbox"/>	<input type="checkbox"/>	<input type="checkbox"/>	<input type="checkbox"/>	<input type="checkbox"/>	<input type="checkbox"/>	<input type="checkbox"/>	<input type="checkbox"/>	<input type="checkbox"/>
Solar panels on roofs or racks	<input type="checkbox"/>	<input type="checkbox"/>	<input type="checkbox"/>	<input type="checkbox"/>	<input type="checkbox"/>	<input type="checkbox"/>	<input type="checkbox"/>	<input type="checkbox"/>	<input type="checkbox"/>
Other (please describe)	<input type="checkbox"/>	<input type="checkbox"/>	<input type="checkbox"/>	<input type="checkbox"/>	<input type="checkbox"/>	<input type="checkbox"/>	<input type="checkbox"/>	<input type="checkbox"/>	<input type="checkbox"/>

Water turbines and solar panels top the charts for most people, and although there is broad support for wind turbines, there are also a small minority with strong views against them.

d) Would you have objections to the development of wind, water or other resources for producing power? Would you object to engine powered generators? If so, over which areas of the island would you object,

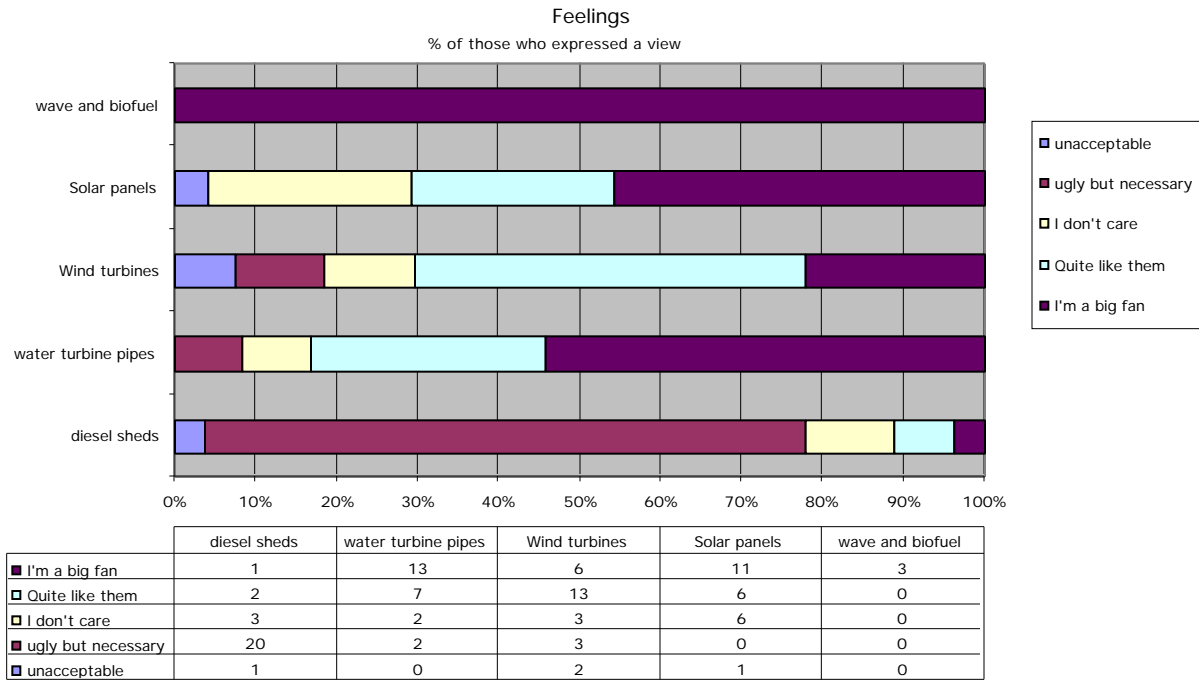

and to which sorts of developments?

Most replies started by saying they would have no objections. Wind turbines must be sited with due sensitivity, and diesels must be soundproofed.

There is a perception that wind turbines could be a hazard to birds. Some felt that renewable energy equipment would add to the character of the island. Certain special areas would not be suitable though.

e) What would be your preferred solution to supplying power to the island while respecting the environment, and also bearing in mind the limited reserves of fuel remaining on the planet? In other words, what is the sustainable option?

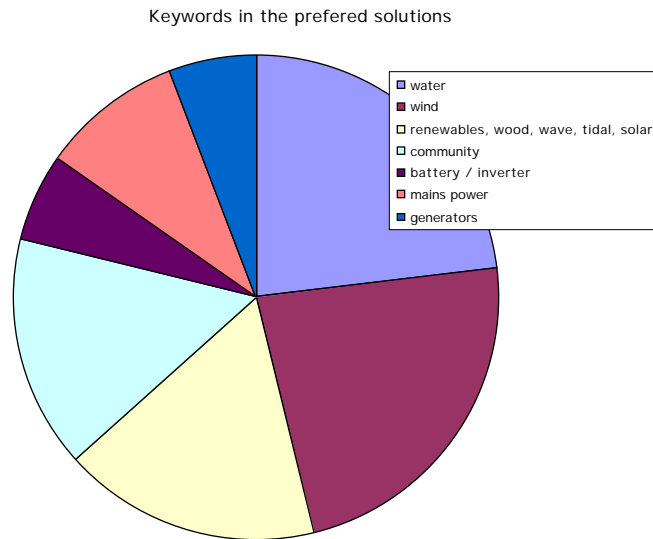

Water and wind power were the most popular, with other renewable energy sources popping up often too. Diesel generators would be maintained for backup purposes.

Several respondents mentioned community schemes, and it appears that the Kildonnán example referred to in the introductory text is regarded as ideal for many people. Some would like a mains grid connection, combined with use of renewables.

3. Electricity supply requirements

Planning for future electricity supplies must be based on some notion of the consumer load, in terms of energy consumption per year or similar statistics. It would be feasible to measure the existing electricity consumption at each point of use and to total this up. Previous reports have used this approach. But experience has shown that electricity consumption depends more on the availability and price than on previous habits.

Energy conservation

It is usually safe to assume that demand will increase over time until all of the affordable energy is used. This process is typical of our consumer society, which is intrinsically unsustainable. In contrast, sustainable strategy will rather use energy conservation measures, to improve our enjoyment of the benefits of electricity while reducing our actual demand for energy.

Consumption will vary considerably, depending on the degree of energy efficiency. For example, low-energy lighting appliances (compact fluorescents) use only 20% of the energy of conventional lamps. Modern appliances can be much more efficient than old ones. Energy efficiency costs money, but it ultimately pays for itself in grid-connected situations, so it will be even more appropriate on Eigg, where the cost of delivering electricity is likely to be higher than on the mainland.

Electric Heaters

The use of electricity for heating is an important variable. Energy for heating is a larger fraction of our energy use than lighting, power and electronics. Where this is met directly by electricity on demand, the cost will be high compared to heating by other means such as burning fuel. A recent report has shown that the island could be self-sufficient in heating fuel from 'biomass' or firewood sources. Another feasible (but secondary) source of heat is from surplus electricity generated from renewable sources at times when demand is low, and batteries are full. It is much cheaper to store energy as heat than as electricity (in batteries).

Where electricity is required to produce heat, then 'heat pumps' should be considered. A heat pump moves heat from the environment into a building using electricity in rather the same way as a refrigerator moves heat out of a box. Each kWh unit of electricity can be used to make 3 kWh of heat available. So the heat pump multiplies the effectiveness of the electricity.

The time factor: connecting batteries to optimise energy usage

In most electricity systems, the energy must be generated at the same rate as it is used. In other words, the generating plant must be large enough to meet the peak power demand on the system. In a renewable energy system, the energy is generated according to the weather rather than on demand. In the absence of storage, a great deal of this energy will be dumped (usually as some sort of useful heat). In order to be large enough to meet peak power demand, the turbine (or whatever) will have to be much larger than the size required to equal the average energy demand.

When generating plant is underused in this way, we can say it has a low capacity factor. Capacity factor can be improved by charging batteries during times of low demand and then using battery power to supplement the turbine during periods of higher demand, or when there is no wind, water or sun. By adding battery storage to the system we reduce the amount of generating plant required to meet the electrical load. This comes at a price. Batteries are expensive and need to be replaced every few years. But they can make a great difference to the capacity factor of a diesel genset or a hydro turbine. And without battery storage, small wind or photovoltaic systems would be virtually useless for electricity supply.

Diversity

Much of the variation in power supply and demand can be removed by using diverse sources of power in a hybrid system (wind and solar combined for example). The greater the diversity of the system, the smaller the battery needs to be. In the same way there is an advantage to having a

number of premises connected to the same supply because the diversity in their usage will even out the peaks of demand. In this case, the cost of the distribution network must be considered against the cost of the battery store. In both cases there are also energy losses to be allowed for.

Peak loads

Meeting peak loads is a challenge for stand alone power systems. The inverter delivers mains voltage power from the battery to the load. Most inverters can deliver about three times their continuous rated power for brief periods. If overloaded they will cut out. Large inverters are expensive. Gensets are often used to help meet peak loads, so as to both save on the cost of the inverter, and also to supplement the energy supply at the same time. Peak loads have often caused reliability problems in systems where the inverter is undersized. Overloaded inverters, and glitches during genset connection, are the cause of low power quality and also loss of power on frequent occasions. To provide a reliable supply it is necessary to be generous with the inverter capacity.

Assessing the load

The potential future electrical load on the island is about as long the proverbial piece of string. A very high standard of living can be achieved with very little electricity use, if appropriate steps are taken toward energy management, efficiency, and alternative heating fuels.

Domestic electricity use of the typical UK household on the mainland grid is approximately 10-12 kWh per day (4,000kWh/year). Present consumption on Eigg is almost certainly less. This figure could be used as a ball park estimate of future energy demand for households on Eigg, while bearing in mind the above comments on ways by which demand could be reduced. Future residential energy demand can therefore be estimated as approximately 120,000 kWh based on the number of inhabited or partially inhabited dwellings.

Commercial premises include the Pier Centre shops and tearoom, and several guesthouses. There is also a school, a doctor's surgery, day care centre, and telephone exchange. These additional loads could increase the overall demand to 200,000 kWh or more.

Factoring the load

To supply 200,000 kWh units of electrical energy to the user on demand, it will be necessary to generate more than this. Energy is lost at every stage: heating up transmission in cables, lost in storage batteries, discarded into heating when the battery is full, and used up during conversion from one voltage to another. To meet a demand for 200,000 kWh it would be necessary to produce 300,000 kWh and also to plan the system carefully to avoid unnecessary waste.

4. The renewable energy resources of the island.

1. Wind Energy

Estimated Annual mean windspeed at 10 metres above ground level.

These figures are taken from the NOABL database/model which can be downloaded from <http://www.bwea.com/noabl/>

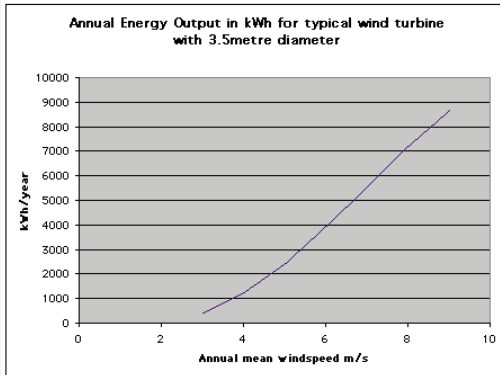

The chart above can be used to estimate annual energy output in kWh units for a small wind turbine on a 10 metre mast.

However the windspeed at any site is highly dependant on local features which may cause shelter and turbulence.

Windspeed is given in metres per second. 4 m/s is 9 mph.
9 m/s is 20 mph.

Existing wind turbines

- 1. Rutland 0.9 m diameter
- 2. Hawks (2) 0.9 m diameter
- 3. Bergey XL 7 m diameter
- 4. AIR 1.2 m diameter

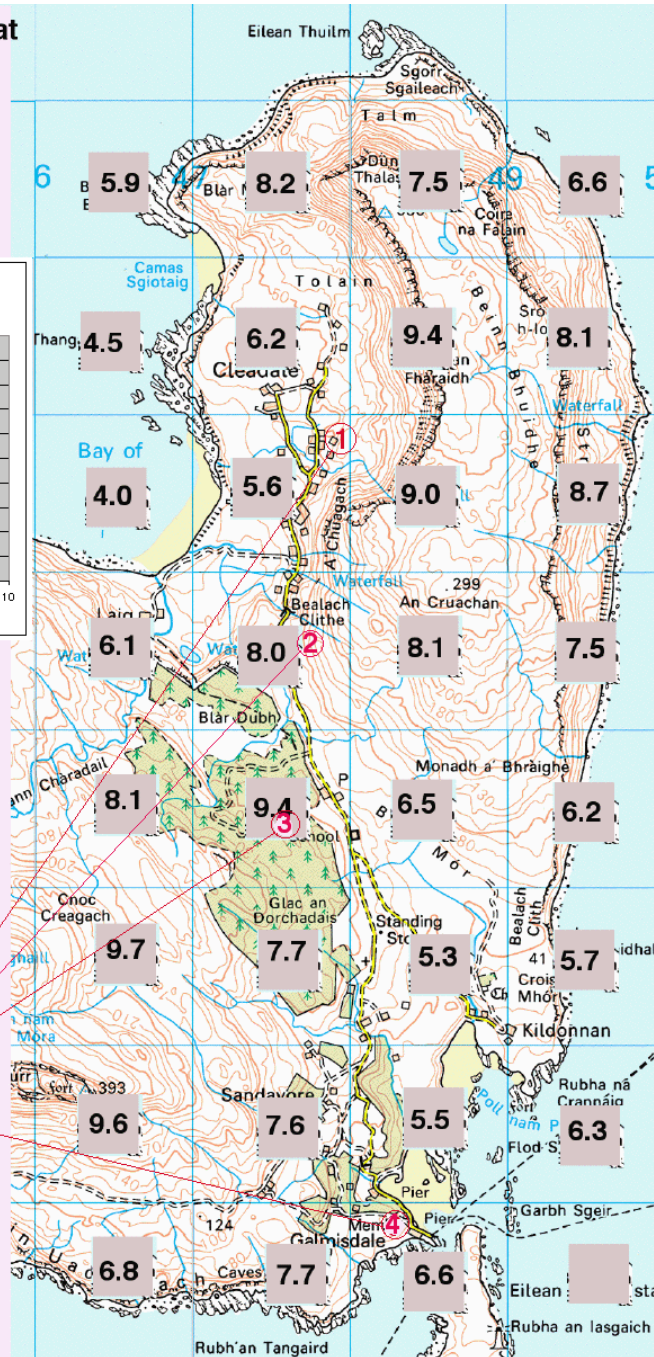

The energy in the wind varies with the cube of the windspeed, so there is very little energy in low winds and a huge surplus in high winds. Annual mean windspeeds on the island are above average (see map), so wind energy is an option worthy of study. But the topography of the island with its many steep slopes makes the wind flow turbulent and hard to model accurately. Turbulent winds are less productive of energy and also cause premature wear and tear of the wind turbine.

There are already five small wind turbines in operation on the island, on four sites.

Table 2.1 gives estimated windspeeds and energy production for these three wind turbines.

Wind Turbine	1	2	3	4
Diameter	.9 m	.9 m	7.0 m	1.2 m
Mean windspeed	5 m/s	7 m/s	8 m/s	6 m/s
Energy/year	185 kWh	370 kWh	28000 kWh	494 kWh

Site windspeeds are difficult to estimate with accuracy, even given the database figures for each kilometre square. Local conditions and height can make a huge difference to the real situation. Actual energy production may be less than the figures given in the above table.

Much could be learned from data-logging exercises, which collected windspeed data at possible future turbine sites, and also logged the energy production of existing windpower systems on the island.

Wind energy systems costs

We can take as an example a 2.5kW wind turbine produced in Scotland by Proven Engineering products of Kilmarnock. This is above average quality and weight for a small wind turbine, and would have a life expectancy of about 20 years on Eigg. During that time, some repairs and overhauls would be inevitable. On a 6 m/s site this turbine would produce approximately 4000 kWh of electricity each year - enough for one house.

Budget costs for 2.5 kW wind energy system	
2.5kW wind turbine/generator (240V output)	£ 3,655
2.5kW 240V heating controller. Volt and Ammeters 500mmHx300Wx200D	£ 660
Tilt-up self supporting wind turbine mast (6.5m) including foundation kit, plans & gin pole	£ 1,625
Tirfor winch with 20 metres wire rope + strop (suitable for WT600/WT2500)	£ 380
Estimated installation cost including 1 cu metre of concrete poured into a hole	£ 1,000
3-core amoured cable for WT2500/120	£ 500
delivery estimated	£ 400
total ex-VAT	£ 8,220



The photo shows a Proven wt2500 on the Scoraig peninsula, in landscape similar to that on Eigg.

2. Solar (Photovoltaic) Energy

Photovoltaics or "PV" is the technology whereby solar cells are used to convert the energy of sunlight directly into electricity. The cells are assembled into panels or 'modules' (see right). Several modules are linked up to make up an 'array' (see next page) for electricity supply on any given site.



PV modules are very reliable, but expensive in terms of the energy available from the sun in Scotland. Output can be predicted with some accuracy, provided the array is sited where there is no shading.

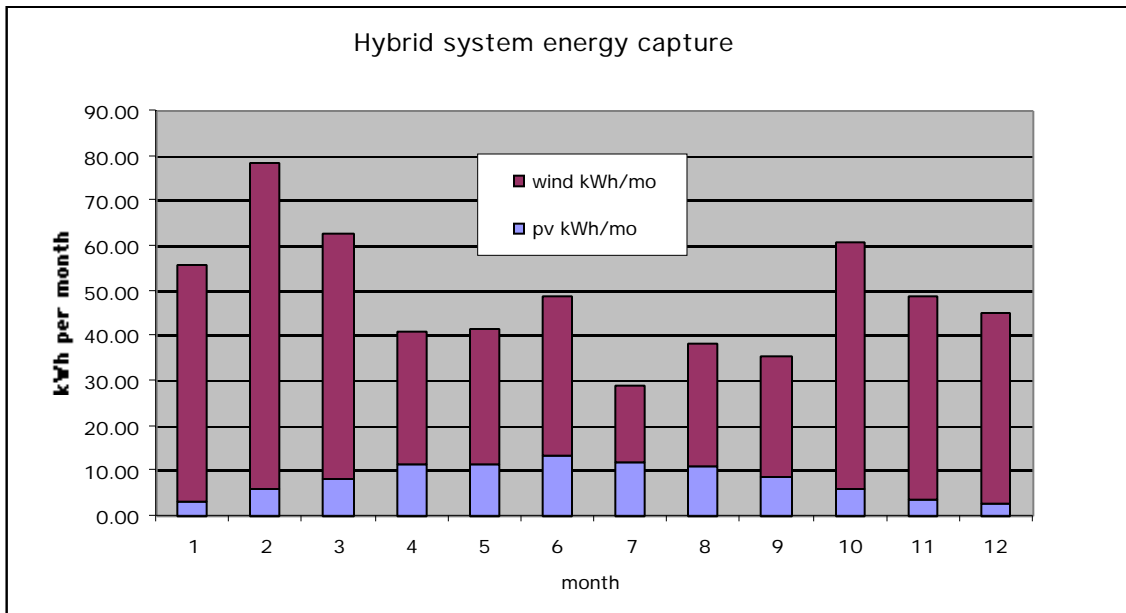

There is a large seasonal variation in energy production. Consider a PV array rated at 1 kW (1000 W) nominal power output. Average annual production will be about 750 kWh each year, so the monthly average will be 62 kWh. But during the darkest months of the winter, this falls to only 12 kWh per month.

Photovoltaics are used to power the lighthouse on Castle Island. PV modules are also in use at the TV repeater station above Cuagach, alongside two small wind turbines. These wind turbines produce more energy than the PV modules per unit cost, but the mixture of wind and solar energy provides a more consistent supply. Solar energy is available in the summer when windspeed tends to be lower. This type of system, where two sources are used is termed a 'hybrid system'. The chart shows typical energy capture for a hybrid system with two 'Hawk' wind turbines and two 75W PV modules.

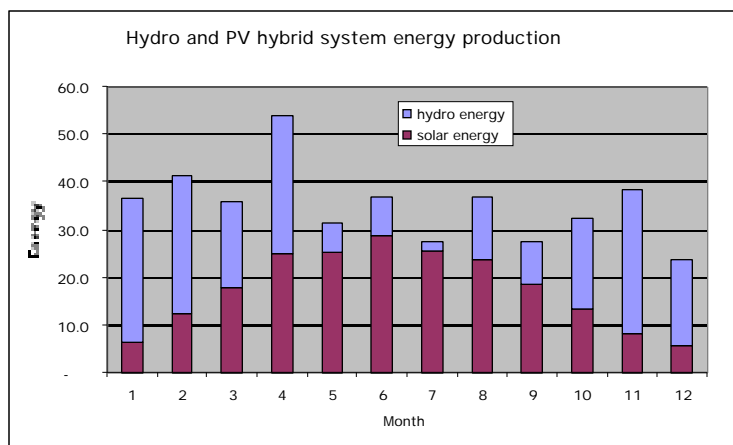

The second chart shows how a photovoltaic array would work alongside a hydro turbine of the sort discussed in the next section. The turbine would run for 60% of the time. The chart shows what the turbine would produce per month (data from year 2000) compared to what the PV array would produce in a typical year. (I suspect that the sun in May 2000 was actually less than average, in view of the high rainfall.) The combined energy output is very consistent over the year, indicating a suitable arrangement for a standalone system, with minimal reliance on the back-up genset.

Photovoltaic System costs

The table shows the cost of a PV system which would produce about 1350 kWh /yr
The array area is 16 square metres.



Budget costs for 2 kW Photovoltaic array	
12 no. 85 Wp photovoltaic modules	£ 8,000.00
Support framework	£ 800.00
DC cabling	£ 150.00
Charge controller with metering	£ 250.00
Fuses etc	£ 50.00
Installation estimated	£ 300.00
Total ex VAT	£9,550.00

3. Hydro Energy

Hydro sites on Eigg

There is a long-standing tradition of using small hydro turbines to produce electricity on Eigg. A highly sophisticated 7kW turbine supplied power to the Lodge for many years before falling into disrepair. Several other sites have been developed in recent years (see map).

The hydro systems on Eigg can be termed as 'pico hydro' because they are under 10 kW in size. Modern pico hydro systems do not need dams or reservoirs. Water is collected from the stream in a small pool created by a low weir, and then returned to the stream below the turbine.

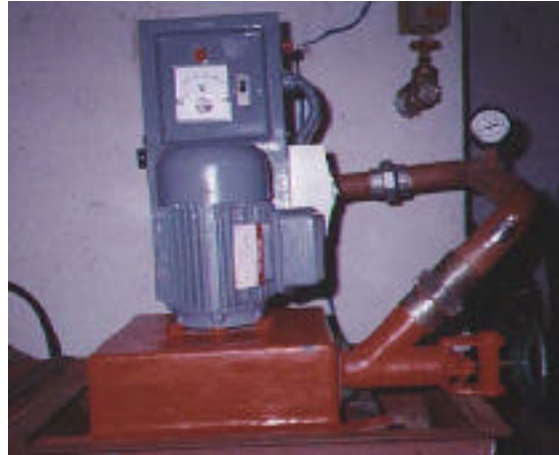

The power output depends on the flow of water, and also the head of pressure. By doubling the vertical fall between intake and turbine, we can double the power obtained from the same flow of water. The cost of this extra 'head' is a longer pipe. The pipe is a large element in the cost of the project. The bore of the pipe has to be large, so that pressure is not lost overcoming friction.

In most cases, the existing hydro systems produce AC power, which is used directly. Surplus power is diverted into heaters so as to keep a constant load on the turbine, and maintain a stable voltage. This ability to produce direct AC sets hydro turbines apart from wind and solar systems, which rely on other equipment such as batteries.

Hydro is much more consistent than wind or solar power, but it does suffer from downtime during the drier weeks of the year.

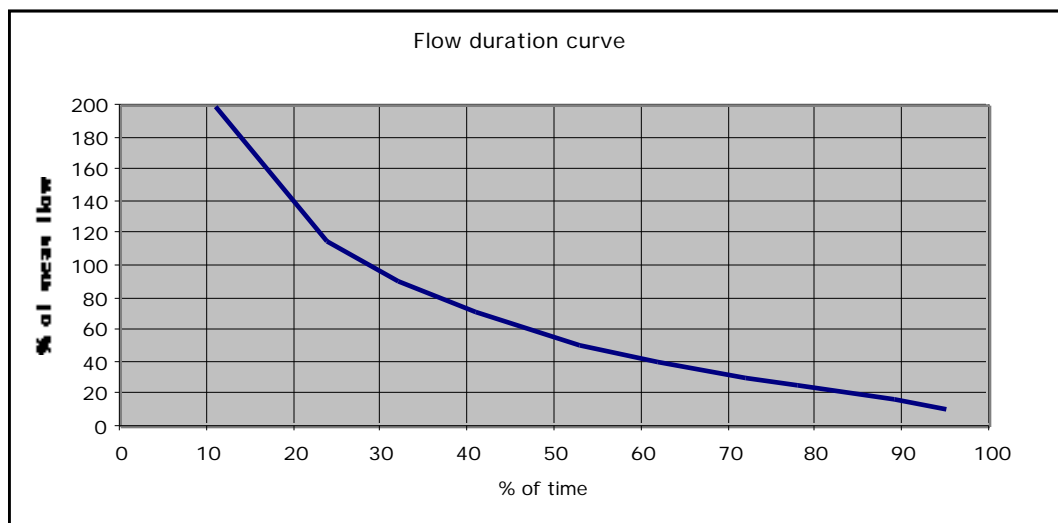

The Flow Duration Curve

The way in which water flow varies can be expressed in terms of a 'flow duration curve' (FDC). A typical flow duration curve is shown above. It shows the percentage of the mean flow which will be exceeded for how much of the time. For example the flow which will be available for 50% of the time (also known as 'Q50') is only about 55% of the mean flow in the stream.

This idealised flow duration curve comes from computer software. It conforms to the expectations of the Environmental Protection Agency (SEPA), but the actual FDC on any given site may vary from this considerably, and will change from year to year. Actual flow measurements will greatly increase our understanding of the potential resource.

Note that the mean flow (shown as 100% on the chart) is only available for 28% of the year. Much higher flows are available for shorter periods, and much lower flows are also very common. The flow, which is available for 95% of the time, is called 'Q95'. Q95 can be estimated as typically 11% of the mean flow. This flow is significant, because it is chosen by SEPA as the minimum 'compensation flow' which should remain in the water course at all times that water is being extracted. In other words, the turbine can only take water for 95% or less of the year, because it must leave a flow equal to the Q95 flow in the stream at all times, for environmental reasons. Where there is uncertainty about the FDC then the compensation flow may be increased to 15% or more of the estimated mean flow.

The Water Framework Directive

Planning applications for pico-hydro developments are subject to scrutiny by SEPA, which in turn has to bear in mind the new 'Water Framework Directive' coming out of Europe in the next few years. This will attempt to prevent **any** environmental impact by any new development on a waterway. If taken literally, this directive could simply prevent future hydropower development. However, the legislation will contain some recognition of the importance of using renewable energy reduce the overall environmental damage we do, in getting our electricity. If a hydro turbine produces benefits to the environment or community, which outweigh the (minimal) environmental damage caused, then this will be taken into account.

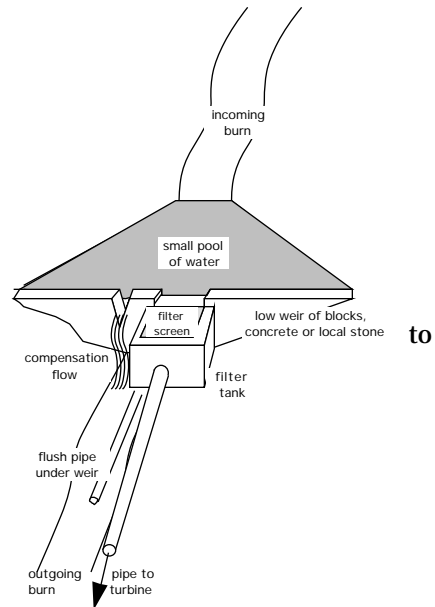

Choosing a suitable size for the turbine

We must take account of the difficulties with both varying flow and official scrutiny, in making our choice of turbine for any site. The cost of the pipe, turbine, controls and cabling will depend on the choice of flow. Traditionally, a turbine is sized to use the mean flow on the site. However this flow is only available for 28% of the time. After removing allowing for compensation, flow this availability is cut down still further to about 24% of the time. This is a poor capacity factor.

We need a consistent energy supply, with as little impact on the flow as possible. I would therefore choose a turbine which only uses 25% of the mean flow.

- This will cost less,

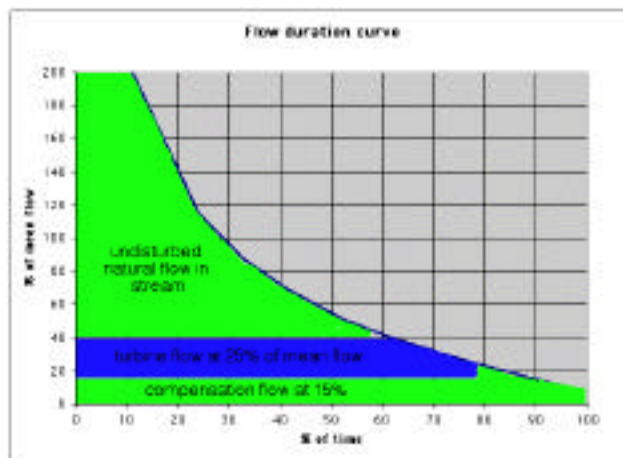

- have lower environmental impact
- and yet operate for over 60% of the time on full power.

This approach produces less energy on a given site, than the larger turbine option. But it produces the energy more consistently, rather than in big bursts during wet weather. And because it is environmentally friendly and low cost, it can be used on more sites, and over higher heads, to capture the island's full pico-hydro potential.

The potential for pico hydro development on Eigg

The map shows the island divided into catchment areas for the purpose of estimating flows at the various sites. Run off can be estimated as 1166mm per year. From this we can derive theoretical flow duration curves for each site, and thence derive specifications for turbines, pipelines and their energy production.

Several of these sites are already in use, and experience indicates that the estimated FDC is very different (better or worse) than the model predicts. Turbines existing on these sites are mostly larger than the size suggested in this report.

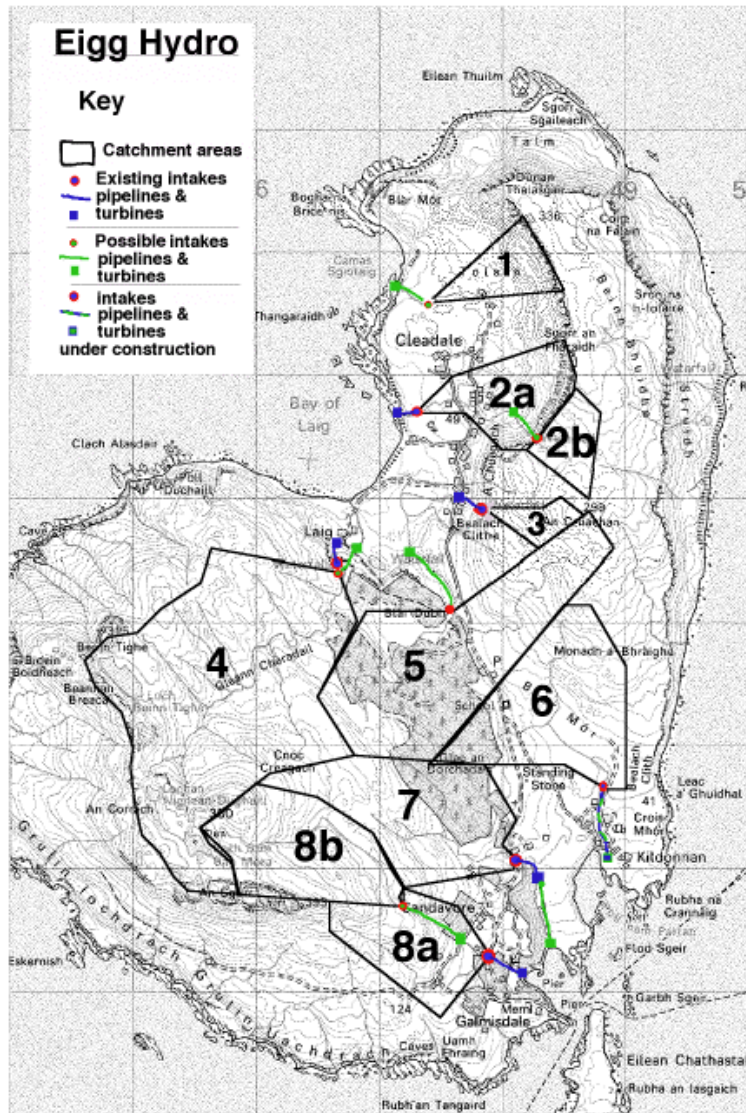

Physical parameters of hydro sites shown on map.							
	<u>Areas</u>	<u>mean flow (ADF)</u>	<u>Gross head</u>	<u>Pipe length</u>	<u>Pipe bore</u>	<u>Turbine size: 60% efficient power at 25% of mean flow</u>	<u>Energy output (using 25% of mean flow)</u>
1	0.35 sqkm	13 l/sec	35	350 m	75 mm	0.7kW	3499 kWh/yr
2b	0.28 sqkm	10 l/sec	180	400 m	50 mm	2.7kW	14398 kWh/yr
2	1.25 sqkm	33 l/sec	18	150 m	105 mm	0.9kW	4628 kWh/yr
3	0.16 sqkm	6 l/sec	90	200 m	40 mm	0.8kW	4114 kWh/yr
4	3.50 sqkm	129 l/sec	30	300 m	187 mm	5.7kW	29995 kWh/yr
5	2.00 sqkm	74 l/sec	40	700 m	167 mm	4.3kW	22854 kWh/yr
6	1.34 sqkm	50 l/sec	30	550 m	144 mm	2.2kW	11484 kWh/yr
7	1.28 sqkm	47 l/sec	17	110 m	115 mm	1.2kW	6216 kWh/yr
7b	1.28 sqkm	47 l/sec	30	550 m	141 mm	2.1kW	10970 kWh/yr
8b	1.05 sqkm	39 l/sec	100	600 m	104 mm	5.7kW	29995 kWh/yr
8	1.80 sqkm	67 l/sec	40	350 m	140 mm	3.9kW	20568 kWh/yr
						total	158721 kWh/yr

It is interesting to note that the theoretical energy output of the combined schemes amounts to over 150,000 kWh per year. This meets half of our energy production target as guess-timated in section 3.

The scenarios given here are not set in stone, and could be adapted in many ways. For example there are sites where a great deal more energy could be collected by extending the pipeline and increasing the head at the turbine (see for example Laig catchment 4). There are also many smaller watercourses, which could for example produce a 200-watt output, contributing perhaps 1000 kWh/year or 1/4 of a typical household demand.

Staying with the above examples, we can put budgetary cost figures on these developments. These costs are based on the 25% of mean flow design rule used for this exercise. Many of the existing systems use more of the flow. Turbine costs are based on importing Australian 'Platypus' turbines, which appear to be very competitive. Research has shown that there are also even cheaper turbines to be had from developing world countries. These may not prove to be such a good investment long term.

Installation costs are very hard to predict, because existing sites have used the owners labour and materials, or volunteer labour. The uncertainties surrounding installation schedules and costs may become a serious obstacle to future development of renewable energy projects on the island.

Budget costs for hydro sites shown on map.					
	<u>Place name</u>	<u>Pipe estimated cost</u>	<u>Turbine (& controller) estimated cost</u>	<u>installation cost estimated</u>	<u>Total project cost</u>
1	sgiotaig	£ 910.00	£ 1,550.00	£ 3,460.00	£ 5,920.00
	0	£ -	£ -	£ -	£ -
2b	tighearna	£ 1,040.00	£ 3,000.00	£ 5,240.00	£ 9,280.00
2	cormack	£ 1,500.00	£ 1,550.00	£ 3,450.00	£ 6,500.00
3	fyffe	£ 300.00	£ 1,550.00	£ 1,885.00	£ 3,735.00
4	laig	£ 3,600.00	£ 4,000.00	£ 9,760.00	£ 17,360.00
5	cam lon	£ 7,000.00	£ 3,800.00	£ 13,840.00	£ 24,640.00
6	kildonnan	£ 4,400.00	£ 3,000.00	£ 8,200.00	£ 15,600.00
7	glebe	£ 660.00	£ 2,000.00	£ 3,780.00	£ 6,440.00
7	gurrabain	£ 4,400.00	£ 2,500.00	£ 8,220.00	£ 15,120.00
	0	£ -	£ -	£ -	£ -
8b	sandavore	£ 4,200.00	£ 4,000.00	£ 9,580.00	£ 17,780.00
8	lodge	£ 2,800.00	£ 3,800.00	£ 7,260.00	£ 13,860.00
				total	£ 136,235.00

4. Wave and Tidal Energy

Wave motion can be used to generate electric power. The technology is well developed, but requires very specific site conditions, which do not exist on Eigg.

Tidal currents can be exploited by underwater turbines similar to wind turbines but smaller in size. The viability of the technology depends heavily on the speed of tidal streams. There are usable flows in the channel between Eigg and Castle Island, but they are not strong enough to make tidal power a tempting option. The need to maintain a clear channel for navigation would probably be another big obstacle to successful exploitation of the resource.

5. The suggested model for electricity supply

1. The options for electricity supply are as follows:

Diesel generators. (gensets)

These are the main source at present and will likely remain a useful part of the mix in future.

Advantages: Power is available on demand. Initial cost is low. The technology is well understood, and a number of diesel sets exist.

Disadvantages: Fuel cost is an ongoing expense. The burning of diesel fuel is polluting and non-sustainable. Plant depreciation and maintenance is costly. Older diesel sets have been extremely reliable but noisy and dirty. They appear to last forever but must eventually wear out. Newer sets are less reliable, and have proved expensive to maintain.

Mains Grid Electricity.

There has never been a mains connection to the island, but a cable could be laid. This would be a popular option with some residents.

Advantages: High reliability with minimal user involvement. The ability to tap into much more efficient generating plant on the mainland. Renewable energy sources on the island could be connected to the grid, allowing surplus power to be exported, or transferred to other users on the island.

Disadvantages: A cable connection would have very high capital cost, even compared to small renewable energy installations. Electricity would still have to be generated elsewhere to meet the island's needs. This would have both financial and environmental costs, which would be ongoing. A mains connection would remove one of the island's many distinctive features, which make it attractive to visitors.

Small renewable energy systems.

Advantages: Renewable energy is abundantly available, free at source and everlasting. The environmental impacts of harnessing it are less damaging than the impacts of conventional fuel-burning plant. Small power systems fit the human-scale character of the island, which is part of its appeal.

Disadvantages: Capital cost of small renewable systems and associated infrastructure is high. The available power does not match demand very well, and additional equipment is required to regulate, store, and convert the energy for the end user. This adds to cost, and reduces the efficiency and reliability of the systems. Maintenance of the systems would fall on local residents rather than an electricity company.

2. The way forward

The questionnaire responses indicated a preference for reliable, non-polluting, 24-hour electricity supplies. Purely private supplies are not very popular, and many would prefer mains electricity. But the most popular option overall was a private supply supplemented by a community scheme.

Reliability. While grid power sets a high standard of reliability, this is not always the case in remote places. Greater reliability can be achieved using a diverse supply, which does not rely on one source alone.

Non-polluting sources were a priority for the islanders, and renewable energy is popular on the island, especially hydropower. Wind and solar power are also attractive although there is some concern about the high visibility of wind turbines.

24-hour electricity is readily available from battery/inverter systems, which store energy and make it available as AC mains-quality power on demand. Many households already operate such systems alongside their diesel generators, and benefit from increased convenience and fuel savings.

The solution which appears to best suit the majority of islanders is a semi-autonomous power system which takes most of its energy input from renewable sources, but uses a battery to maintain 24-hour power, and a diesel generator to provide backup. The diagram shows the structure of the system in its general form.

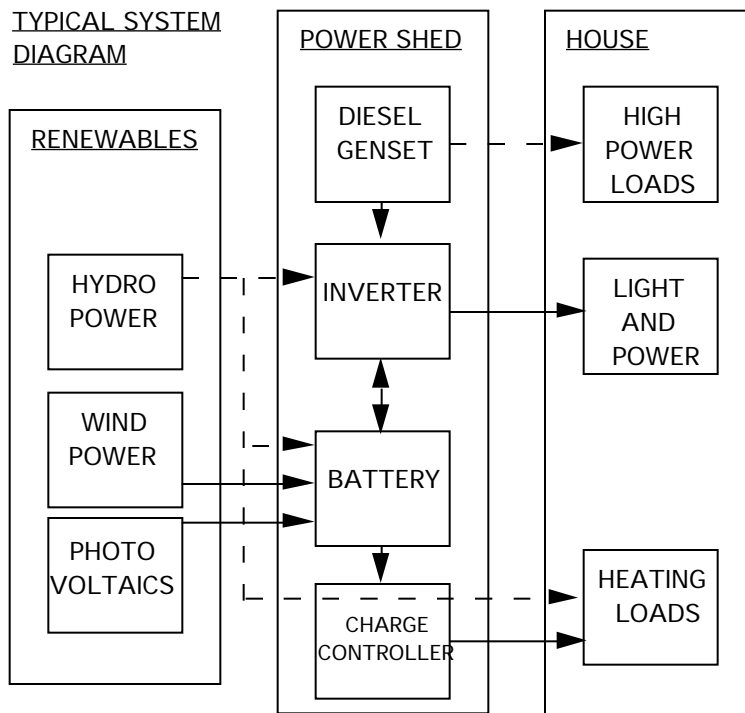

The inverter

The inverter provides 24-hour power for lights and power. The inverter is a device, which converts DC battery power into AC mains-quality power.

Some modern inverters

have the facility to synchronise with an AC supply such as a genset, and to use that supply to feed the user load directly. Meanwhile the inverter actively smoothes out the load on the AC source (genset, hydro, etc) by using part of it to charge the battery when user demand is low, and by taking power from the battery during periods of high demand. This makes the best use of the supply and prevents overload of the source. While this inverter operating mode is routine for a number of gensets on the island already, it has not yet been tried with a hydro turbine. The system at Kildonnan, which is shortly to be commissioned, will be a test case for this innovative approach to using hydropower.

The battery

This takes energy from such renewable sources as are available, and stores it until it is needed.

The charge controller

This monitors the state of the battery and diverts any incoming energy that the battery cannot store (due to lack of capacity) into useful heating loads in the building.

The diesel genset

This provides power when the battery becomes discharged or the demand in the house is beyond what the inverter can meet. When the diesel generator is running, it recharges the battery at the same time as directly supplying the user demand. The inverter serves as a battery charger during this phase of the operation. On most sites there is already a genset in operation, which makes the transition to the new arrangements easier.

Renewable energy sources

Wind and solar power may be available in the form of DC to charge the battery. In the case of some hydro turbines, AC mains-quality power which can be used directly. In the latter case it would be desirable to feed hydropower through a synchronous inverter without converting it into battery power at all. Converting the energy results in some of it being lost as waste heat.

3. Stand alone system costs

Each domestic stand-alone power system will be costly because of the need for battery storage. But batteries greatly improve the capacity factor of the renewable energy sources. Without the batteries, any energy which is generated at the wrong time would have to be discarded, and replaced later with diesel generated power at times of high demand. The battery systems make renewable energy 'go further'. Economic analysis must allow for the future replacement of batteries at approximately five year intervals. It therefore makes sense to rely on genset backup rather than having such a huge battery that it can deal with the worst case scenario.

Location of batteries at each site enables the user to access relatively high power from the system without the need for a very expensive distribution system. PV modules can be located close to the battery, but wind and hydro turbines can be located where the wind or water supply is best. Cables carry power from the turbines to the dwelling at high voltage.

Budget costs for a stand alone domestic supply	
4.5kW inverter/charger	£ 3,000.00
15kWh battery	£ 1,800.00
Cabling and fuses	£ 200.00
Bypass switch for generator	£ 160.00
5kW Diesel generator	£ 4,500.00
Installation	£500.00
Total ex VAT	£10,160.00

In most cases some or even all of this equipment already exists at Eigg households. But the equipment specified here is larger than existing systems. This would improve reliability, by reducing the danger of overload, which has been a frequent cause of power failure in the past. Commercial users (Shop and tearoom for example) should consider using a 10 kW inverter in place of the existing 2.5 kW.

4. Island wide system outline with costs

One possible scenario to consider...

The table below is an illustration of what could be achieved, at lower cost than a grid connection, to power the island in a sustainable way.

Budget costs for a system to meet the island's needs					
Item	Cost	Energy kWh/yr	no.	total cost	Total kWh/yr
Domestic stand-alone systems	£ 10,160	1,000	35	£ 355,600	35,000
Photovoltaic arrays 2kW each	£ 9,550	1,350	35	£ 334,250	47,250
Hydro turbines	£ 13,000	16,000	10	£ 130,000	160,000
Wind turbines	£ 8,220	4,000	16	£ 131,520	64,000
			tot:	£ 951,370	306,250

In this scenario, each house has a stand-alone system with a 2kW photovoltaic array, which provides 1350kWh of energy per year. This energy is likely to be delivered at times when water and wind power are less plentiful.

The diesel generator might provide 1000 kWh. This represents about 4-5 hours running per average week. The generator should have a long service life on this duty.

Hydro and wind turbines at suitable sites are used to provide the bulk of the energy to meet our target of 300,000 kWh each year (see section 3). The costs of the wind and hydro systems have been adjusted to allow for long cables to reach the houses.

This is only an illustrative scenario and does not prescribe the positions of the turbines. The distribution of good sites does not match the distribution of dwellings very well. It is hard to supply the population centre in Cleadale and the area around the Glebe.

There is ample hydropower around Sandavore and Laig. There are ample sites for wind turbines west of Galmisdale, and these could be sensitively placed. It may be harder to find many other sites which are not only suitable, but acceptable, and close enough to the dwellings. Blar mor and the slopes above Cuagach are suitable but rather inaccessible.

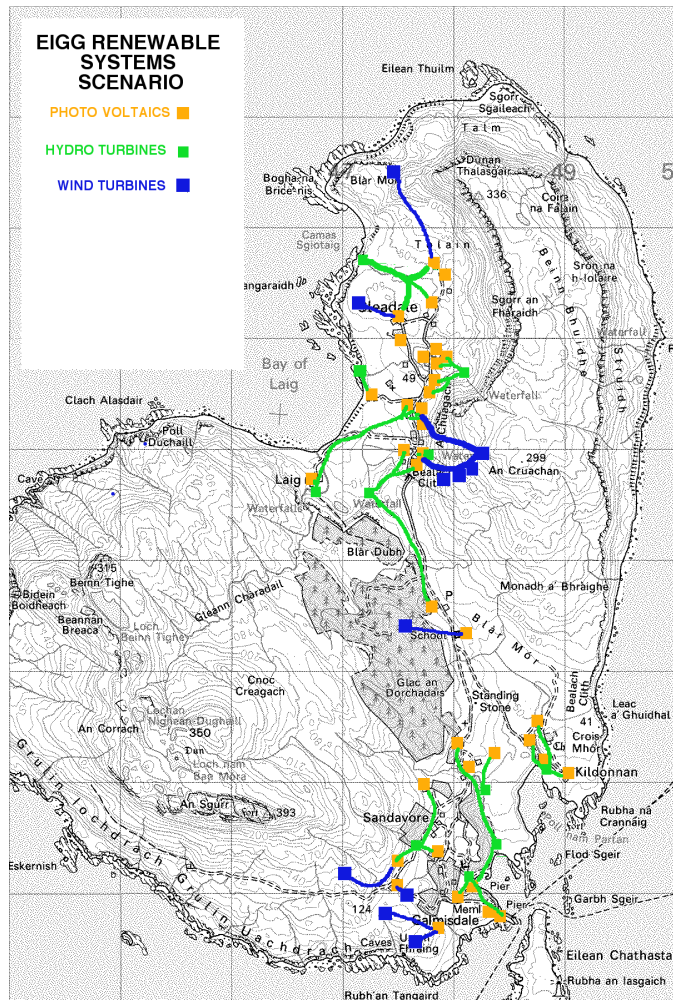

Planning permission

The scenario above would be tackled in small increments, each of which would be subject to planning permission, including conditions imposed by Scottish Natural Heritage and SEPA.

There are Sites of Special Scientific Interest (SSSIs) on the island where the hazel and willow scrub and the arctic sandwort deserve special care. This should not be an insuperable obstacle. The whole island is a National Scenic Area. Visual impact of developments will be critical. It should be easy enough to blend the small hydro systems into the landscape, but the effects on flow in waterfalls needs to be negotiated. Small wind turbines will have to be placed where they will not be conspicuous. Short towers and natural colours should make this possible.

Normally residents would be classed as very sensitive to development, but since all the power will be used on the island that aspect may have to be reconsidered. Questionnaire responses indicated that noise and visual impact concerns were low on the scale of priorities for energy supply.

Economic analysis

The cost of the above scenario appears to be under half of the cost of a mains cable, and 90% of the energy produced is from renewable sources. Each house has reliable 24-hour power.

However it would be wise to be cautious until we have more accurate costings for installation work on the island. Previous installations have relied heavily on voluntary labour and have been very slow to progress. Onerous conditions which may be imposed through the planning process could multiply the cost.

Some sources are more cost-effective than others according to the above figures. But the more expensive elements play a vital role in maintaining continuity of supply.

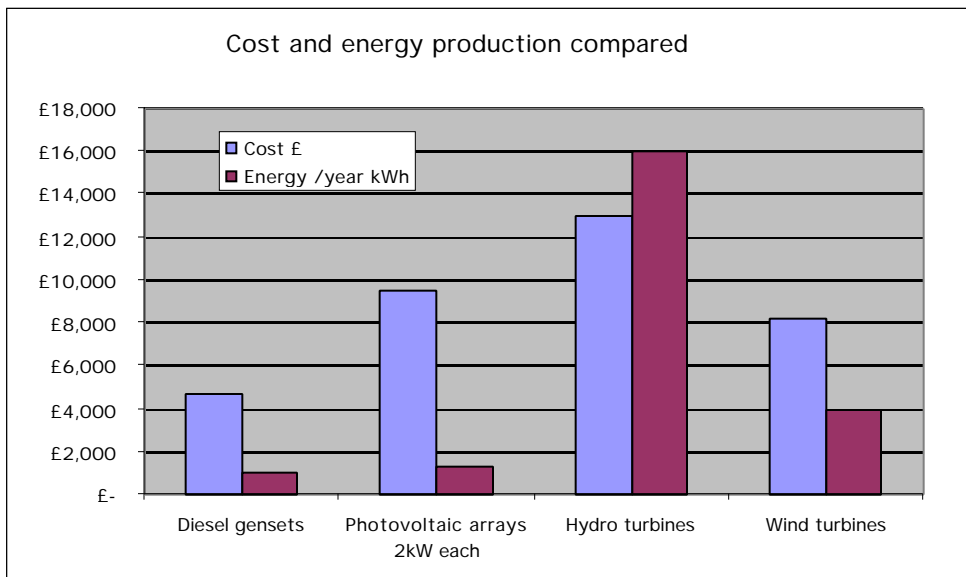
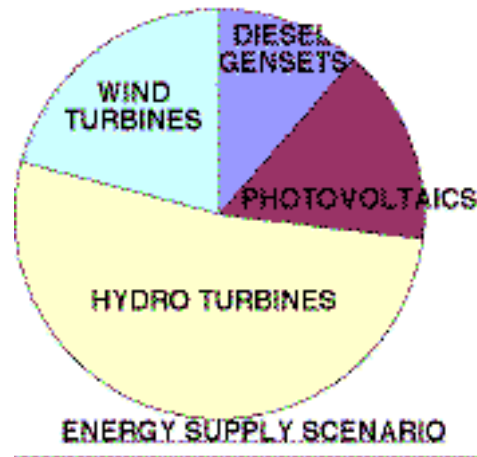

Conclusion

Demand for electricity will probably increase on Eigg in future years, even allowing for energy efficiency measures. Residents will also expect 24-hour power, with better reliability than has been acceptable in the past. This increased expectation can be met to a large degree from renewable energy sources. The cost would be less than the cost of grid connection. At present there are very generous grants available to assist with this type of development.

The strategy described in this report builds on the style of existing electricity supply arrangements on the island, and could be implemented gradually. Experience gained along the way would contribute to the effectiveness of later developments. Inadequately sized equipment has caused considerable problems in the past, but new developments could afford to be more generous.

The process would offer sustained employment opportunities on the island in both the areas of installation and maintenance. The availability of labour could however be the main factor limiting the pace of development. In fact there is a national shortage of expertise in small renewable energy system manufacture and installation.

There is a need for more data to be collected, by manual observations or datalogging equipment. We need to know more about the energy production from existing systems, as well as the actual resources available for future development, such as windspeeds and the flows at various points in local streams. The data will help us identify the most cost-effective solutions and avoid possible environmental damage.

Eigg is an ideal situation for testing and demonstration of cost-effective small-scale renewable energy systems. Development of environmentally friendly systems could put Eigg in the forefront of electricity supply technology for the 21st century.

Hugh Piggott, Scoraig, January 2003